



CE

WATER HEATERS EVO

ENG TECHNICAL DOCUMENTATION

ENG TABLE OF CONTENTS

1. PRECAUTIONS AND WARNINGS
2. USE AND PRINCIPLE OF OPERATION
3. CONSTRUCTION
4. DIMENSIONS
5. TECHNICAL DATA
6. ASSEMBLY
7. ACCESSORIES
8. TERMS OF WARRANTY
9. CONNECTION SCHEMES
10. WARRANTY CARD

1 PRECAUTIONS AND WARNINGS

- Before use and assembly of goods it is essential to read the following manual.
- The Producer reserves the rights to make changes in the following manual without previous notice.
- In order to assembly the device it is essential to contact with the qualified person.
- Water heaters cannot be used by children or disabled people.
- The Producer is not responsible for the damages which occur due to unauthorized changes, improper assembly or incompatible use.
- Always make sure that the supply is compatible to the current safety rules.
- Always assemble water heaters due to the current and local safety rules.
- Do not use these units if they are broken, if such circumstances occur, please turn the device off the supply and contact with the Producer or responsible individual.
- The water heaters should be installed by the qualified person with certification for water and electrical installations.
- The duct size must be chosen by the designer.
- All works should start from switching off all sources of energy to prevent electrocution.
- Enter for installation with dry hands and with shoes on.
- Please remember that inlet and outlet of water heaters should be available and do not cover them.
- Water heaters NeoAir are not adapted for work in wet, dust environment or in inflammable places.
- To protect the unit it is recommended to assemble the filter on hydraulic inlet.
- It is recommended to install the protection from the pressure increase.
- It is recommended to install the residual current device (RCD) in electric installation.
- It is recommended to install vent valve in the highest place in hydraulic installation and cut off valves on inlet and outlet of the unit.

- Please remember that the water heaters do not have the anti-freeze protection. It is essential that the temperature in room does not go below 0°C. You can protect the installation with the mix of water and glycol, please remember about proportions of these liquids, which are recommended by the producer. While using the anti-freeze factor the unit has lower capacity. To protect the heater from freezing you can take out the water.
- It is essential to check leakiness of the water installation before first start.
- Water heater is the heating unit, particular elements may be heated.
- Waste utilization should be proceeded due to the valid norms in the country.
- We would like to remind to maintain the devices. The coil can be cleaned by compressed air.
- Please remember to cut off the electrical installation and disassemble the fan before cleaning it.
- Fan blades and grid should be cleaned regularly.

ATTENTION!!! Water heater NeoAir is delivered with closed air stators, before the first use open the air stators with both hands on sides. Otherwise the fan may damage.

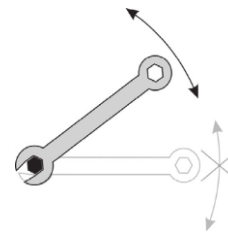

ATTENTION!!! While screwing exchanger to pipeline connecting stubs has to be hold by wrench.

Producer / Distributor / Seller is not responsible for damages caused by unobserved rules included in this manual.

2 USE AND PRINCIPLE OF OPERATION

Water heaters units can be assembled on walls or under ceilings in large volume rooms like: warehouses, garages, shops, workshops, production halls ect. in order to heat these rooms. The devices should not be used in dusty environments and in corrosive ones to metals such as iron, copper or aluminum. The heaters are not suitable for external use.

Water heater with the flow heating coil, which heating carrier is hot water. The heat is changed and released through very efficient 1, 2 or 3 rows heat exchanger and is blown out by fan. When the hot water is turned off the water heater works as an ventilation unit.

3 CONSTRUCTION

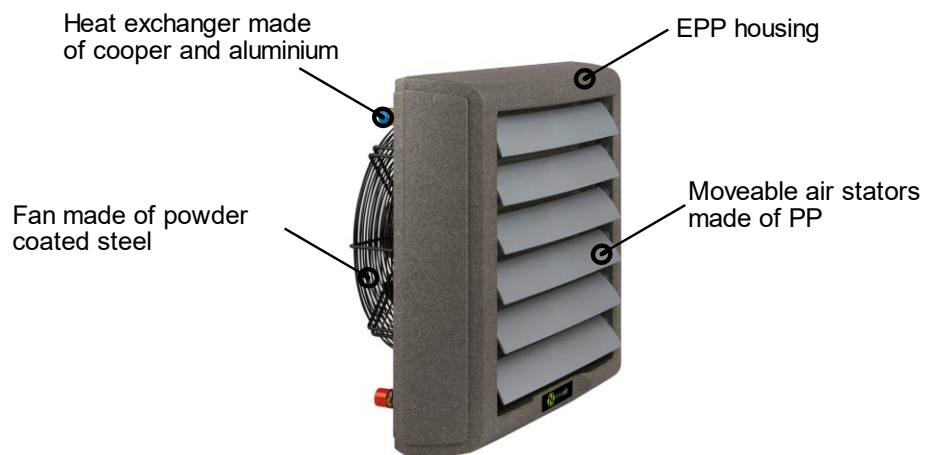

4 DIMENSIONS

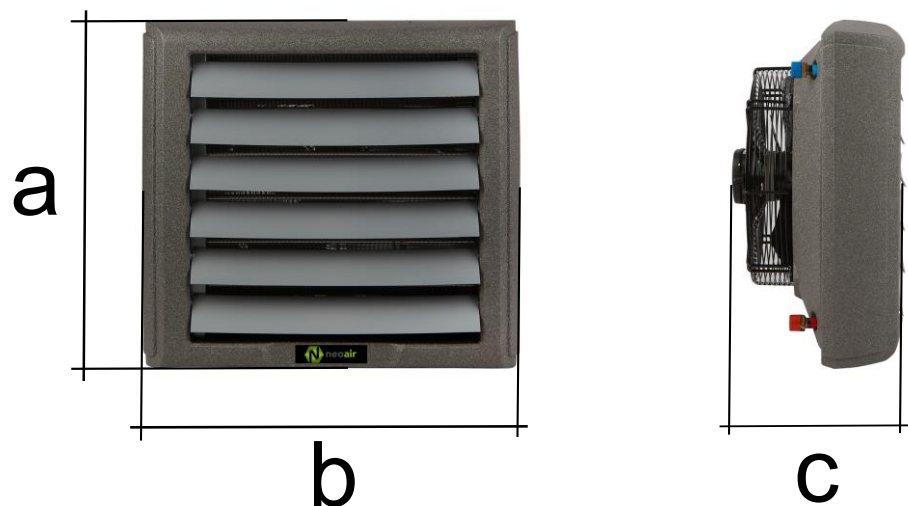

DIMENSION	EVO 35	EVO 42	EVO 49	EVO 65	EVO 69	EVO 108
a [mm]	597	597	597	597	697	697
b [mm]	645	645	645	645	748	748
c [mm]	322	322	322	322	338	338

5 TECHNICAL DATA

PARAMETER		EVO 35	EVO 42	EVO 49	EVO 65	EVO 69	EVO 108
MAXIMAL HEATING CAPACITY[kW]	III stage	35	42	49	65	69	108
	I stage	1400	1300	1100	1000	1800	2300
	II stage	2200	2000	1700	1500	2400	3500
AIRFLOW[m³/h]	III stage	3200	3000	2700	2500	4000	4200
	I stage						
	II stage						
NO OF ROW [-]		1	1	2	2	2	3
MAXIMAL WORKING TEMPERATURE [°C]		130	130	130	130	130	130
MAXIMAL WORKING PRESSURE [MPa]		2	2	2	2	2	2
DIAMETER OF CONNECTORS ["]		3/4	3/4	3/4	3/4	3/4	3/4
VOLTAGE/ FREQUENCY [V/Hz]		230/50	230/50	230/50	230/50	230/50	230/50
NOMINAL CURRENT [A]	III stage	0,8	0,8	0,8	0,8	1,1	2,1
ROTATIONAL SPPEd [RPM]	III stage	1380	1380	1380	1380	1360	1380
MOTOR POWER [kW]	III stage	0,19	0,19	0,19	0,19	0,25	0,46
IP DEGREE [-]		54	54	54	54	54	54
NET WEIGHT [kg]		12	12	13	14	18	23
NOISE [dB]	III stage	< 56	< 56	< 56	< 56	< 60	< 62

The tables on the following pages show the heaters parameters which depend on the supply / return temperatures and the inlet air temperature for the 3rd speed.

EVO 35, III stage	130/110					85/70					75/55					65/45					55/45				
Inlet air temperature [°C]	0	5	10	15	20	0	5	10	15	20	0	5	10	15	20	0	5	10	15	20	0	5	10	15	20
Outlet air temperature [°C]	30	34	38	42	46	19	22	26	30	34	14	18	22	26	29	11	15	19	23	26	12	15	19	23	27
Heating capacity [kW]	35	33	31	29	28	21	20	18	16	15	16	15	13	12	10	13	11	10	8	7	13	12	10	8	7
Water flow [m³/h]	1,54	1,46	4,38	1,3	1,22	1,26	1,15	1,06	0,96	0,96	0,72	0,65	0,57	0,5	0,44	0,57	0,5	0,43	0,36	0,3	1,15	1,01	0,87	0,74	0,6
Resistances of exchanger [kPa]	14	13	11	10	9	10	8	7	6	5	4	3	2	2	1	2	2	1	1	1	9	7	5	4	3

EVO 42, III stage	130/110					85/70					75/55					65/45					55/45				
Inlet air temperature [°C]	0	5	10	15	20	0	5	10	15	20	0	5	10	15	20	0	5	10	15	20	0	5	10	15	20
Outlet air temperature [°C]	39	43	46	50	53	24	28	31	34	38	18	22	25	29	32	15	18	21	25	28	15	18	22	25	28
Heating capacity [kW]	42	40	38	35	33	26	24	22	20	18	20	18	16	14	12	16	14	12	10	8	16	14	12	10	8
Water flow [m³/h]	1,87	1,76	1,66	1,57	1,47	1,52	1,4	1,28	1,16	1,04	0,87	0,78	0,69	0,61	0,53	0,68	0,6	0,52	0,43	0,35	1,39	1,22	1,05	0,89	0,72
Resistances of exchanger [kPa]	20	18	16	15	13	14	12	10	8	7	5	4	3	3	2	3	3	2	1	1	12	10	7	5	4

EVO 49, III stage	130/110					85/70					75/55					65/45					55/45				
Inlet air temperature [°C]	0	5	10	15	20	0	5	10	15	20	0	5	10	15	20	0	5	10	15	20	0	5	10	15	20
Outlet air temperature [°C]	50	53	56	59	62	31	34	37	40	43	24	27	30	33	36	19	22	25	28	31	19	22	25	28	31
Heating capacity [kW]	49	46	43	41	38	30	28	25	23	21	23	21	19	17	14	19	16	14	12	10	19	16	14	12	10
Water flow [m³/h]	2,16	2,04	1,92	1,81	1,7	1,77	1,62	1,49	1,35	1,21	1,02	0,92	0,82	0,72	0,63	0,81	0,72	0,62	0,52	0,43	1,63	1,43	1,24	1,05	0,86
Resistances of exchanger [kPa]	15	13	12	11	9	10	9	7	6	5	4	3	2	2	1	2	2	1	1	1	9	7	5	4	3

EVO 65, III stage	130/110					85/70					75/55					65/45					55/45				
Inlet air temperature [°C]	0	5	10	15	20	0	5	10	15	20	0	5	10	15	20	0	5	10	15	20	0	5	10	15	20
Outlet air temperature [°C]	72	75	77	79	82	46	48	50	52	54	37	39	41	43	45	30	33	35	37	39	29	31	33	35	37
Heating capacity [kW]	65	62	58	55	52	41	38	35	32	29	33	30	27	24	21	27	24	21	18	16	26	23	20	17	14
Water flow [m³/h]	2,89	2,73	2,58	2,43	2,28	2,42	2,23	2,04	1,86	1,69	1,46	1,32	1,19	1,06	0,93	1,19	1,06	0,93	0,8	0,68	2,27	2,0	1,74	1,49	1,25
Resistances of exchanger [kPa]	63	57	51	46	41	45	39	33	28	23	18	15	13	10	8	13	11	8	6	5	43	34	27	20	14

EVO 69, III stage	130/110					85/70					75/55					65/45					55/45				
Inlet air temperature [°C]	0	5	10	15	20	0	5	10	15	20	0	5	10	15	20	0	5	10	15	20	0	5	10	15	20
Outlet air temperature [°C]	48	51	55	58	61	30	33	37	40	43	24	27	31	34	37	20	23	26	29	32	19	22	25	28	31
Heating capacity [kW]	69	65	62	58	55	44	40	37	34	30	35	32	28	25	22	29	25	22	19	16	28	24	21	18	15
Water flow [m³/h]	3,06	2,9	2,74	2,58	2,43	2,56	2,36	2,16	1,97	1,79	1,53	1,39	1,24	1,11	0,97	1,25	1,11	0,97	0,84	0,7	2,4	2,12	1,84	1,58	1,31
Resistances of exchanger [kPa]	39	35	32	29	25	28	24	21	17	14	11	9	8	6	5	8	6	5	4	3	26	21	16	12	9

EVO 108, III stage	130/110					85/70					75/55					65/45					55/45				
Inlet air temperature [°C]	0	5	10	15	20	0	5	10	15	20	0	5	10	15	20	0	5	10	15	20	0	5	10	15	20
Outlet air temperature [°C]	72	74	76	79	81	45	47	50	52	54	37	39	41	43	45	30	32	34	36	38	29	31	33	35	37
Heating capacity [kW]	108	102	96	91	85	68	63	58	53	48	55	50	45	40	35	45	40	35	30	26	43	38	33	28	24
Water flow [m³/h]	4,79	4,53	4,28	4,03	3,79	4,0	3,69	3,38	3,09	2,79	2,41	2,19	1,97	1,75	1,54	1,98	1,75	1,54	1,33	1,12	3,76	3,32	2,89	2,47	2,06
Resistances of exchanger [kPa]	68	62	55	49	44	49	42	36	30	25	19	16	13	11	8	14	11	8	6	5	46	36	28	21	15

6 ASSEMBLY

- Istnieje możliwość montażu jednostki na ścianie lub pod sufitem.
- Zachowaj minimalną wolną przestrzeń między urządzeniem, a sufitem 0,2m przy montażu podsufitowym oraz 0.5 m przy montażu naściennym.
- Do montażu zaleca się użycie konsoli stałej lub konsoli obrotowej sprzedawanych oddzielnie. Prosimy o przestrzeganie odległości pokazanych poniżej.

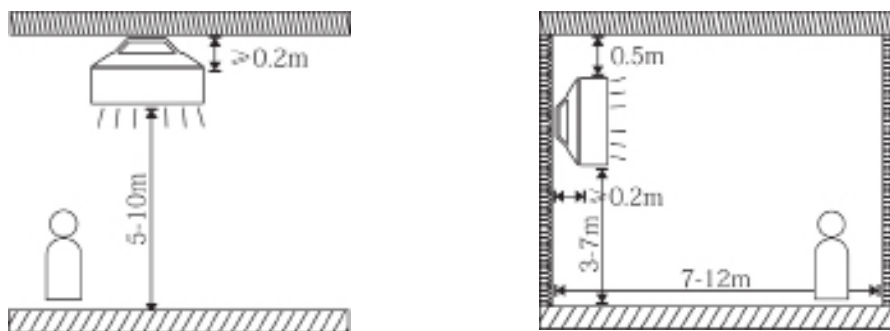

CEILING ASSEMBLY

WALL ASSEMBLY

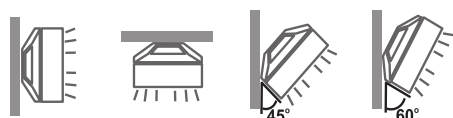
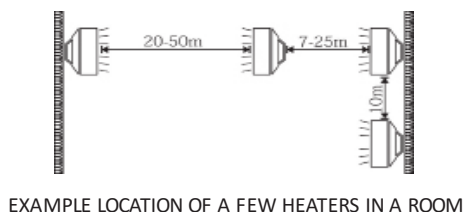

ADJUSTING THE LEVEL OF INCLINATION OF THE HEATER USING A ROTATIONAL MOUNTING BRACKET

7 ACCESSORIES

- Speed regulator RS 3,0 A - 5-stage controller is used to operate the single-phase fans. It possesses the on/off switch key. Rated current 3,0 A. Supply 230/50 V/Hz. Its dimensions: 86/166/91mm.
- 3-step controller with room thermostat RSW - enables to control 3 stage fans. It has manual room thermostat with temperature range 10 - 30°C and switches which allow to choose the stage, ON or OFF state and HEAT or COOL mode. Rated current 3 A. Supply 230/50-60 V/Hz.

- Thermostat RS - it is used to keep the constant temperature in the room it has got the temperature sensor. Working temperature is 0 - 40 degrees, control 10-30 degrees. Supply 230V.
- Programmable thermostat RS - it is used to keep the constant temperature in the room. Adjustable temperature control up and down. LCD display, 9 independent programmes, precision to 0,2 degrees. Voltage free relay.
- Valve with actuator RS - it is used in hydraulic installation in order to cut off the water supply.
- Rotational bracket - construction used to assemble units to the walls or under the ceiling. Facility to adjust the rake angle in about 45 and 60 degrees. Horizontal steering possible.

8 TERMS OF WARRANTY

1. The supplier of water heaters is NeoAir Sp. z o.o. [Ltd.]
2. The warranty period begins on the date of purchase and lasts 24 months.
3. Condition of the realization of warranty claims is presenting in the warranty card completed by the installer and the proof-of-purchase (invoice, receipt ect.).
4. During the warranty period the Producer will remove the defects, which are caused because of the material or production faults.
5. The Producer will answer to the request immediate, but no longer than 14 days after receiving the written notification of complaint and the device.
6. All faults acknowledged by the Producer as needed to be repaired will be removed from the faults or replaced within a period specified by the Producer.
7. Warranty benefits will be made in the following conditions: correctly selected, assembled and used units due to the manual NeoAir and overall usage of electromechanical devices.
8. Buyer's rights due to this warranty does not exclude, limit or suspend Buyer's rights which arise from inconsistency of the products with the contract.
9. All additional agreements and statements need to be set written under pain of nullity.
10. The warranty does not include damages to the improper use (e. g. in moist environment, low temperature, insulated., maintenance different than recommended or installed incompatible to this manual) and parts wearing due to exploitation.

230 V / 50 Hz

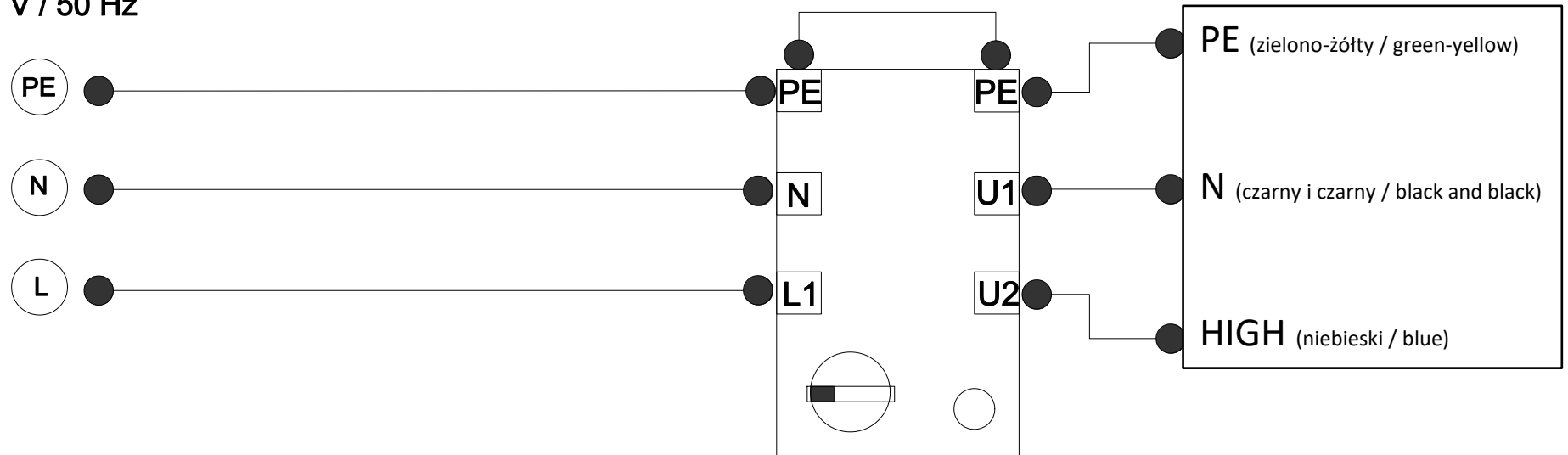

230 V / 50 Hz

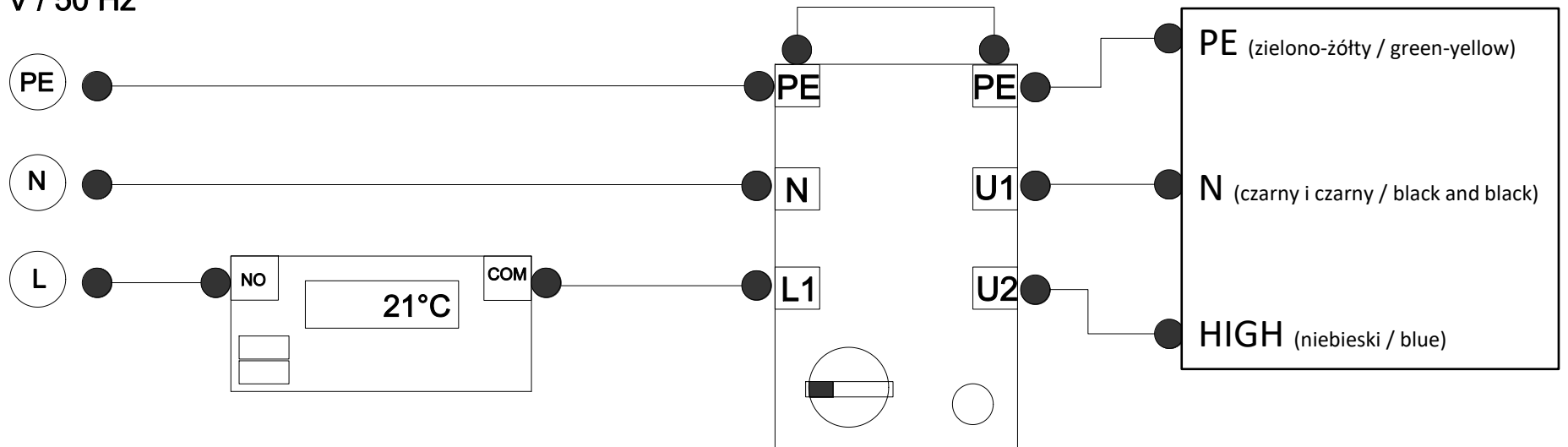

230 V / 50 Hz

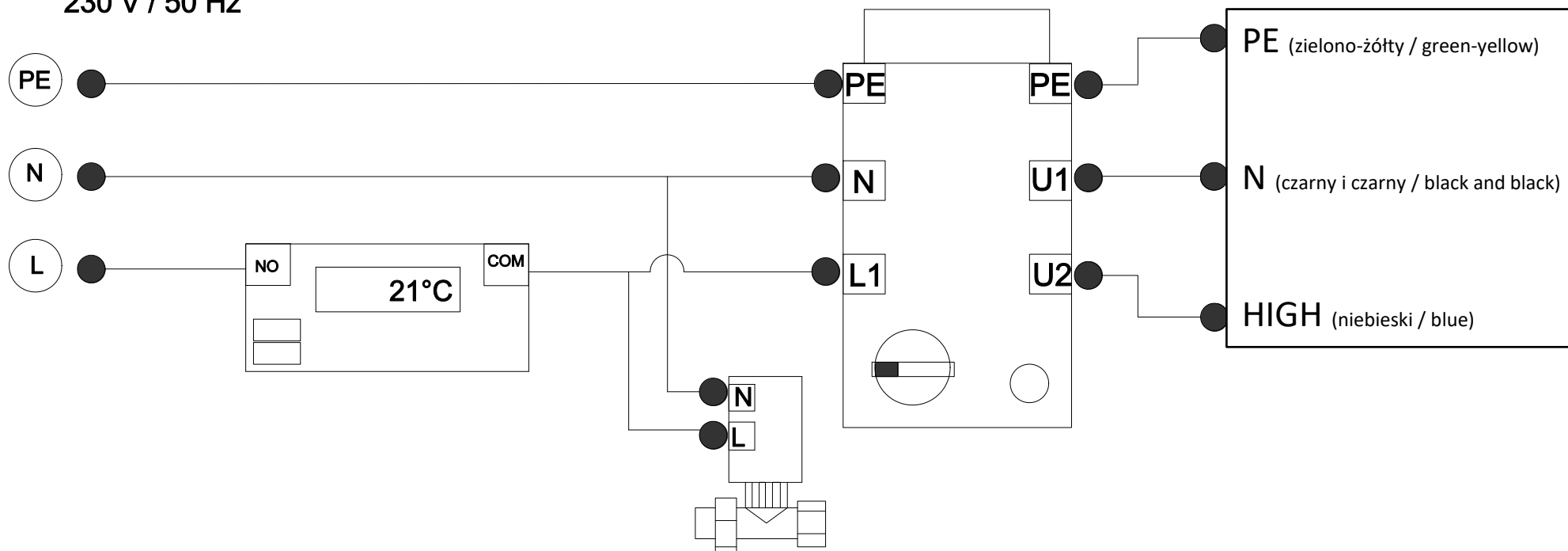

230 V / 50 Hz

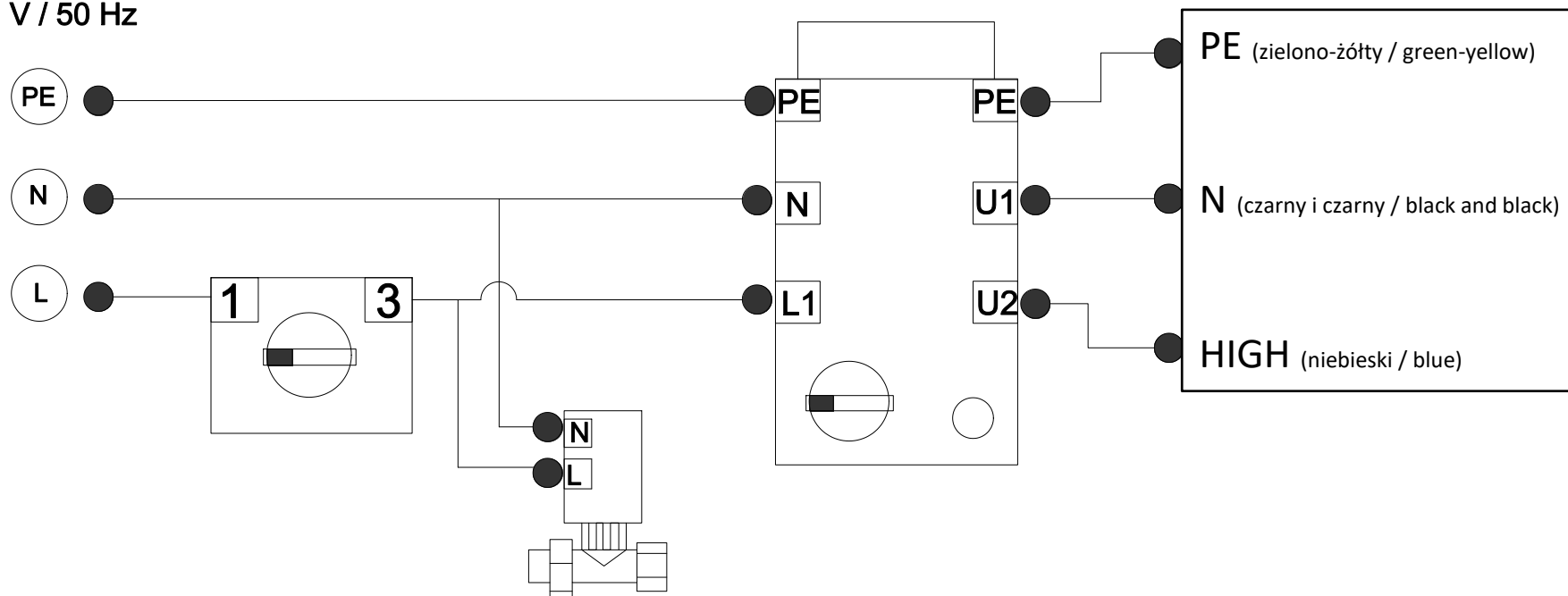

230 V / 50 Hz

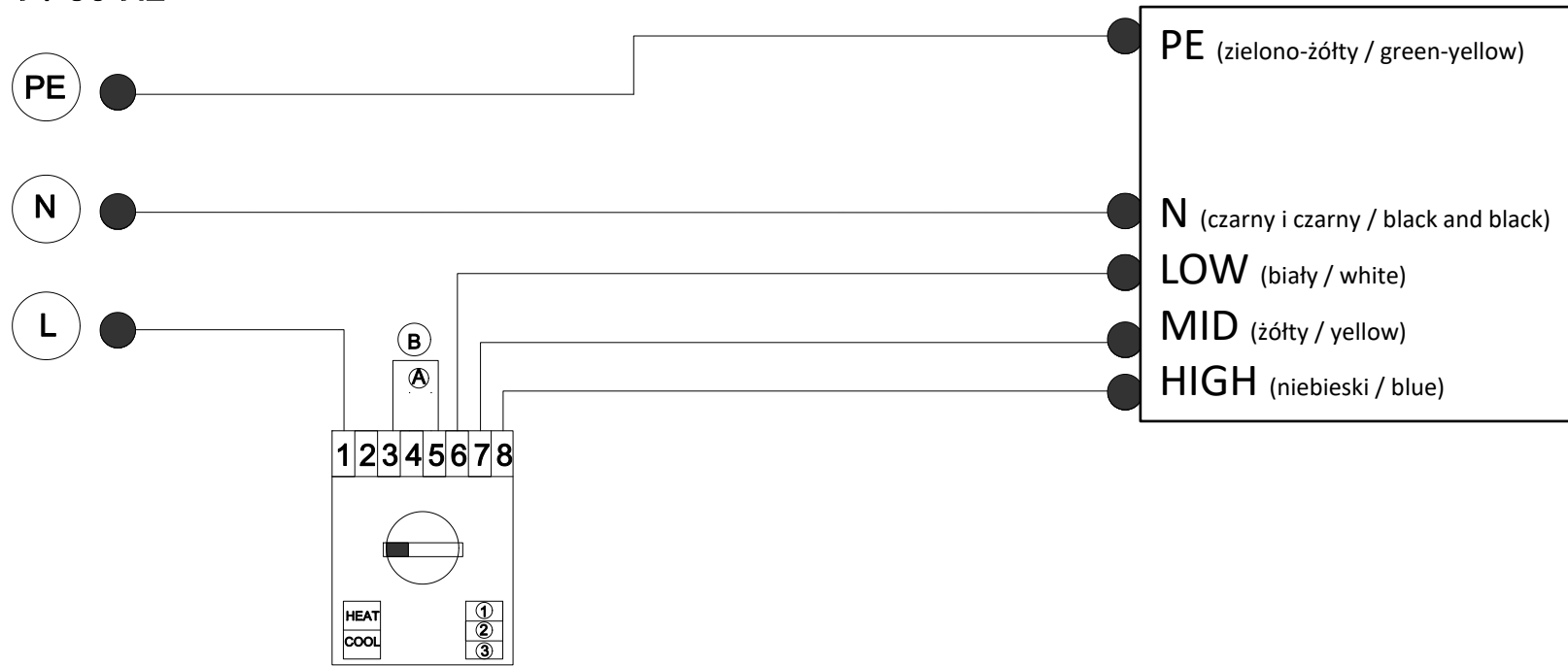

230 V / 50 Hz

